

Water Heater



micro

Installation instructions

Inhaltsverzeichnis

Safety Instructions	3
General Notes Prior to Installation	5
Accessibility	5
Dimensions	5
Hydraulic Diagrams	6
Installation	7
Vibration Dampers	7
Fuel Supply	7
Positioning the Exhaust System	7
Power Supply	7
Installation Steps	7
Step 1: Preparing the Exhaust Floor Penetration	8
Step 2: Install Connections (Before Pipe Installation) – While Unit Is Not Yet Installed	8
Step 3: Removing the HeatMate® Control Unit (if required)	9
Step 4: Position and Secure the micro	9
Step 7: Applying Silicone to the Exhaust Pipe	9
Step 5: Equipotential Bonding on the Heater Unit	9
Step 6: Exhaust Floor Penetration	9
Step 8: Fitting the Fresh Air Hose over the Exhaust Pipe	10
Step 9: Connecting the Exhaust Pipe to the Heater	10
Step 10: Connecting the Fresh Air Hose to the Heater	10
Step 11: Inserting the Exhaust Pipe through the Floor Penetration	10
Step 12: Connecting the Fresh Air Hose to the Floor Penetration	10
Step 13: Mounting the Silencer Under the Vehicle	11
Step 14: Connecting the Exhaust Pipe to the Silencer	11
Step 15: Connecting the Exhaust End Piece	11
Step 16: Connecting the Lines	11
Step 18: Installing the HeatMate® control unit	12
Step 19: Connecting the power supply	12
Filling and Bleeding the System	13
Antifreeze	13
Flushing Unit	13
Step 2: Instructions for Flushing the System	13
Step 1: Connecting the Lines	13
Step 3: Bleeding the System	14
Step 4a: Establishing Operating Pressure (Closed Systems Only)	14
Step 4b: Setting the Expansion Tank Level (Open Systems Only)	14
Step 5: Starting Circulation and Re-Bleeding	14
Commissioning	15
Step 1: Starting the Heater Unit	15
Step 2: Starting the Burner	15
Step 3: Heating the System	16
Step 4: Testing Domestic Hot Water Heating	16
Troubleshooting	16

Legal regulations for the installation of the heater

For installation, the provisions of Annex 7 of the ECE regulation must be observed first and foremost.

Note:

The provisions are binding within the scope of the ECE regulations and should also be observed in countries where there are no special regulations!

Extract from ECE regulation R122 - Appendix 7:

- When installed, the heater must bear a manufacturer's plate with the name of the manufacturer, the model number and the type designation as well as the rated heating output in kilowatts. The operating voltage and electrical power must also be indicated.
- A clearly visible indicator light in the operator's field of vision must show whether the heater is switched on or off.

Extract from ECE regulation R122 - Part I

5.3.2 Arrangement of the heater.

5.3.2.1 Parts of the bodywork and other components on the vehicle in the vicinity of the heater must be protected from excessive heating and possible contamination by fuel or oil.

5.3.2.2 The heater must not present a fire hazard even when overheated. This regulation is deemed to have been complied with if an appropriate distance to all parts was maintained during installation and adequate ventilation was provided or fire-resistant materials or heat shields were used.

5.3.2.3. in the case of vehicles of categories M2 and M3, the heater shall not be located in the passenger compartment. However, installation in the passenger compartment is permitted if it is located in an effectively sealed housing which also complies with the requirements of paragraph 5.3.2.2.

5.3.2.4 The plate referred to in paragraph 4 of Annex 7 or a duplicate shall be affixed in such a way that it is still easily legible when the heater is installed in the vehicle.

5.3.2.5 The location of the heater shall be such as to minimize the risk of injury to persons and damage to property carried.

Disposal of old appliances

The disused appliance must be disposed of at the end of its service life in accordance with national regulations. We recommend that you contact a company specializing in waste disposal or contact the waste disposal department of your local authority.

WARNING!

To prevent misuse and the associated hazards, make your old device unusable before disposal. To do this, disconnect the device from the mains supply and remove the power cord from the unit. For the disposal of the device, please observe the regulations applicable in your country and local municipality.

WARNING!

The procedures for installing the heater contained in this document are recommendations from the manufacturer and may not be suitable for the specific local conditions at hand. Installation must be carried out by qualified personnel, and individual steps may need to be adapted based on the specific circumstances.

WARNING!**Danger due to electric current!**

The heater may only be operated using properly installed individual sockets with protective grounding (Schuko).

Do not pull the power cord by the cable to disconnect it from the socket; always grasp the plug housing.

The burner components and terminals carry 230 V voltage.

The heater must be secured on the vehicle side with a grounded plug. The power supply must meet the specific requirements of the heater.

**WARNING!**

Switching on the heater without heating water can lead to the destruction of the heating system.

DANGER:**Risk of death or serious injury due to improper installation or repair!**

Improper installation or repair of the heater can cause fires or the release of deadly carbon monoxide, leading to severe or fatal injuries.

Only personnel trained by the manufacturer may perform installation or repairs.

Follow all installation and repair instructions.

Observe all warning notices.

All necessary technical documentation, tools, and equipment must be available in the vehicle.

ATTENTION!

Risk of malfunction or device damage due to frost!

If the fresh water in the heating circuit freezes, device damage may occur.

If there is a risk of frost, the fresh water must be drained from any heating system equipped with a plate heat exchanger. The heating system must never be operated without a glycol mixture!

ATTENTION!

Failure to comply with the following installation conditions will result in the loss of warranty and liability claims.

Legal regulations for installation must be followed.

If the heater is to be operated in a separately installed mobile heating system, an installation plan must be submitted to SCHEER for approval in advance. **Without this approval, installation is not permitted.**

ATTENTION!

The specific installation conditions of the respective vehicle type must be observed.

The heater should be installed as low as possible to ensure automatic venting of the heater and the circulation pump. This is particularly important for non-self-priming circulation pumps.

The heater can also be installed in a storage compartment. The storage compartment must be sufficiently ventilated from the outside to ensure that a maximum temperature of 85 °C within the installation enclosure is not exceeded.

During installation, the space required for maintenance access (e.g., removal of the burner) should be taken into account.

ATTENTION!

SCHEER assumes no liability for defects or damages resulting from installation by untrained personnel.

General Notes Prior to Installation

To prepare for the installation of the heating system, the most important guidelines are described below to ensure smooth installation, setup, and operation. It is recommended to observe these steps before installing the heater.

All SCHEER heaters for the mobile sector can be operated with either closed, pressurized or open, pressure-less heating circuit installations. Closed, pressurized installations are advantageous because they eliminate the need for constant monitoring of the heating fluid at the expansion tank. The antifreeze cannot evaporate, and bleeding the system is very simple.

Accessibility

In general, ensure there is sufficient accessibility to the side connections and the maintenance cover of the burner (front side). To allow for the disassembly of the burner during maintenance, a minimum of 25 cm of free space is required in front of the device.

Optimal accessibility to the burner is achieved by placing the heater facing toward a storage compartment hatch. This allows the burner to be removed toward the front without obstruction.

The exhaust gas and fresh air intake run pipe-in-pipe and are connected at the side. The minimum bending radius is 12 cm.

Dimensions

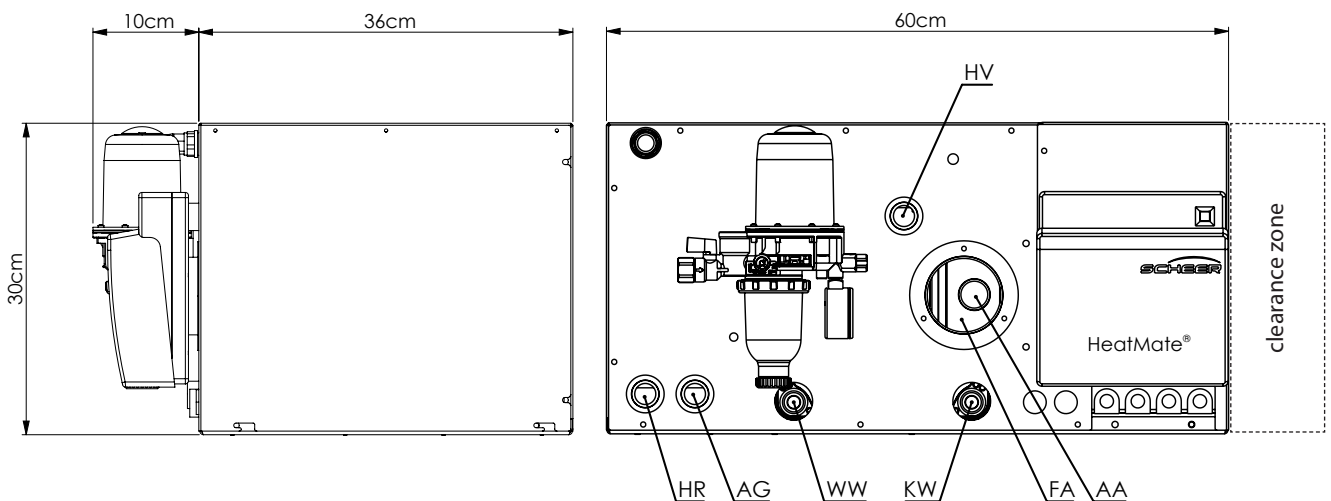

Abbreviation	Description	Connection
HV	Heating water – supply	G1/2" female thread
HR	Heating water – return	G1/2" female thread
KW	Fresh water – inlet	G1/2" female thread
WW	Fresh water – outlet	G1/2" female thread
AG	Expansion Vessel Connection	G1/2" female thread
AA	Exhaust connection	Ø35mm
FA	Combustion fresh-air inlet	Ø75mm

Basic

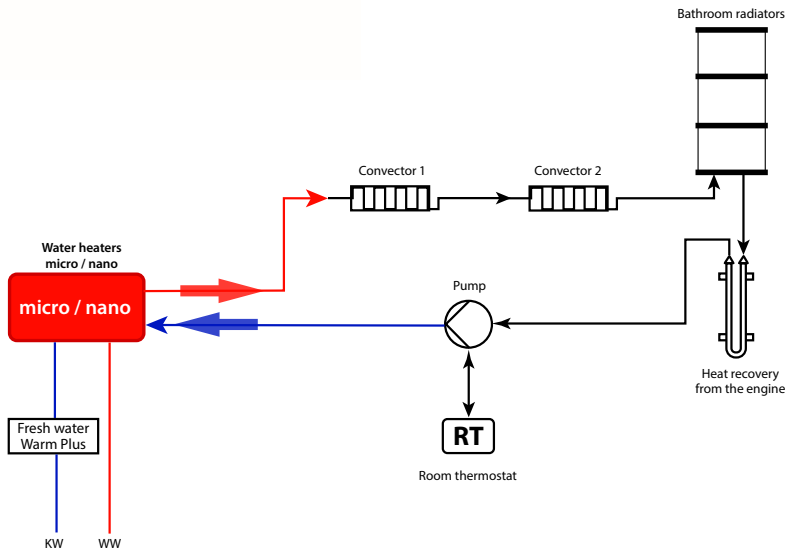

Base with underfloor heating

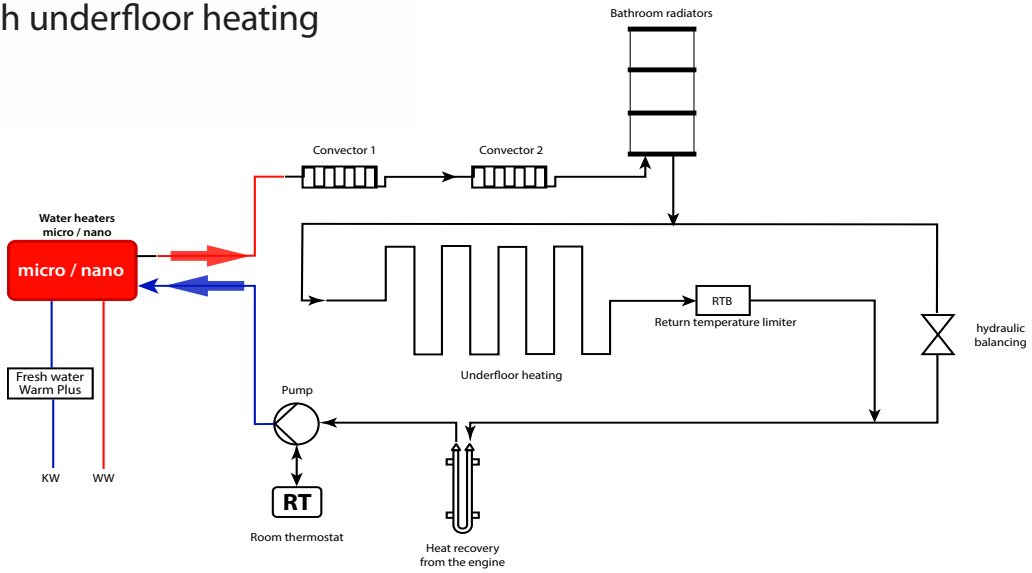

Comfort

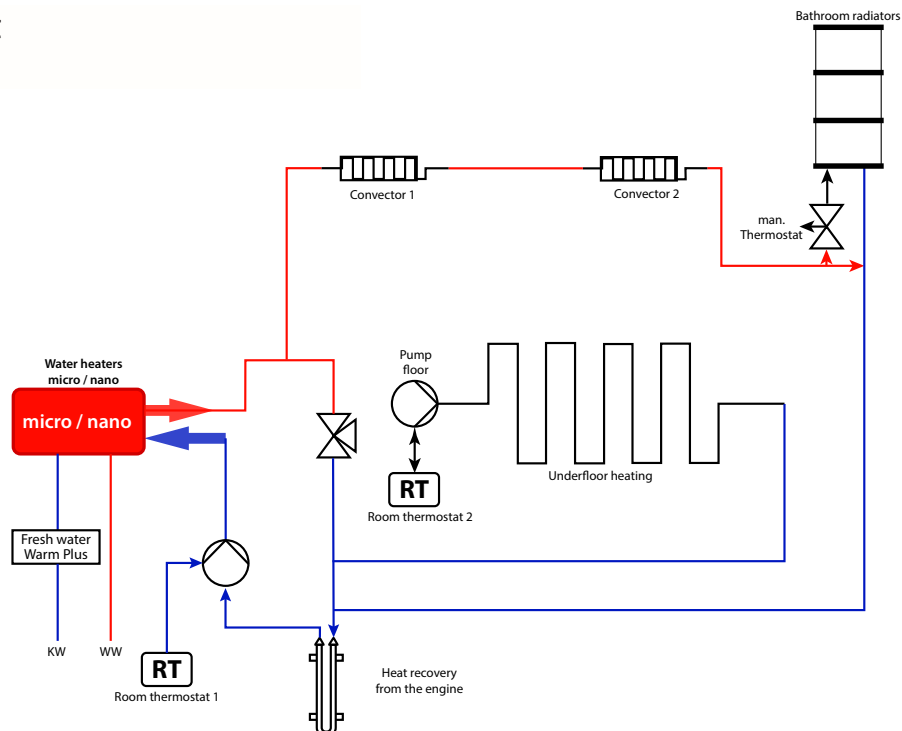

Installation

Any piping system approved for heating applications can be used, such as multilayer composite pipes (plastic or aluminum), copper, stainless steel pipes, or EPDM hoses. Please observe the installation instructions of the respective manufacturer (e.g., minimum bending radii, material compatibility with glycol, etc.).

Warning: Plastic hose barbs tend to become brittle and should be avoided!

For easy filling, a double-T connection with shut-off valves must be provided in the heating circuit flow (immediately at the heater). Good accessibility is essential for a quick filling process.



Vibration Dampers

To dampen the vibrations to which the heater is exposed in the vehicle, installation on vibration-damping components, such as a damping mat (not included in the scope of delivery), is recommended.

Fuel Supply

A diesel fuel line must be laid from the tank to the heater with an inner diameter of at least 4 mm. Fuel extraction must never occur below the vehicle's reserve level (consider the installation of tank sensors, etc.). The fuel line for the heating system recommended flexible and must be approved for diesel fuel. The maximum length of the fuel line is 10 m. An additional fuel pump is not required.

Positioning the Exhaust System

Prior to installation, the positioning of the exhaust system must be taken into account. If the exhaust is to be installed underneath the vehicle, ensure there is sufficient space (refer to the 'Accessibility' section for details)

Power Supply

- The burner components require 230 V AC. A suitable inverter (min. 300 W) is a prerequisite. The „HeatMate®“ control unit is supplied with 9–36 V DC.
- All SCHEER heaters for mobile applications are equipped with a 3 kW heating element (230 V) and can be operated as a hybrid system (diesel and/or electric). The heating element must be protected with a 16 A fuse.
- Equipotential bonding to the vehicle's chassis ground must be established.

Installation Steps

The following installation instructions serve as general recommendations from the manufacturer. Installation must only be carried out by qualified specialist personnel. In the event of deviating assembly steps due to specific local conditions, careful adjustment to the respective environment by experts is required.

The exhaust installation described in Step 7 is an example of downward exhaust routing, including an externally mounted silencer and an exhaust end piece.

Step 1: Preparing the Exhaust Floor Penetration

A through-hole (75 mm) must be created through the floor or the mounting surface. When positioning, ensure that the minimum bending radius of the exhaust and fresh air hoses is maintained according to the manufacturer's specifications (12 cm). The feed-through must be executed taking into account the exact installation location as well as the exhaust and fresh air connections on the device.

The exhaust pipe must be installed with a continuous downward slope to prevent the backflow of condensate.

Step 2: Install Connections (Before Pipe Installation) – While Unit Is Not Yet Installed



Remove the pre-installed blanking plugs from the heating and domestic water connections. Then screw in and seal the appropriate installation fittings on the heating system (fittings depend on the selected piping system).

The supplied connection and accessory kit includes two hose connectors for 22 mm hoses (e.g. Alde hoses) for the flow and return lines, as well as the air vent.



The automatic air vent must be connected to the air vent port of the heater using a suitable angled pipe (not included). Ensure that the air vent is mounted in an upright position above the heater to guarantee proper functionality. Air and small amounts of escaping fluid will be discharged through the transparent hose.

If space is limited, a manual air vent can be installed in the same port instead. Both the automatic and manual air vents are included in the delivery scope.



A connector suitable for the fuel line being used must be used at the fuel filter (not included in the scope of delivery). A recommended internal diameter of 4 mm is specified for the fuel line. The heater requires a separate, direct fuel extraction from the tank. Integration into the supply lines of other consumers is not permitted in order to ensure operational safety.

The included silicone hose (2 m) must be mounted to the filter vent and routed to the outside to prevent diesel odors

Step 3: Removing the HeatMate® Control Unit (if required)

The HeatMate® can be disassembled if it facilitates installation or if separate housing of the unit is necessary.

To do this, disconnect the HeatMate® electrical connectors from the heater. Then, remove the fastening screws that secure the HeatMate® to the heater.

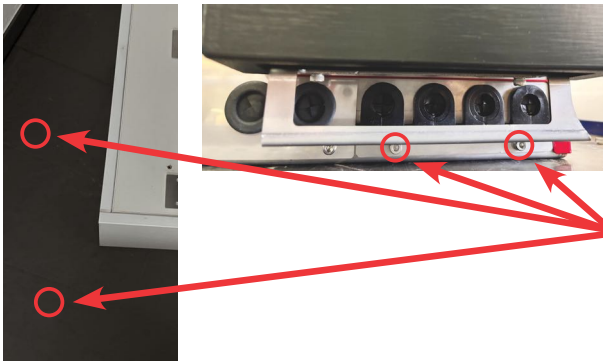

Remove Screws

Step 4: Position and Secure the micro

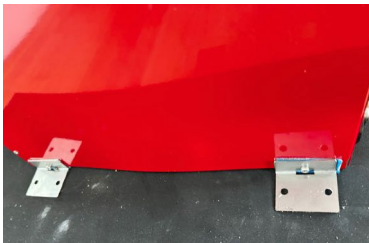

Place the heater at the intended installation site using vibration damping (see section „General Installation Notes“). Next, secure the heater using the supplied mounting brackets.

The brackets can be flexibly mounted to suitable screw points on the housing. Ensure that the heater is properly secured with at least three mounting brackets to guarantee a stable installation.

Step 5: Equipotential Bonding on the Heater Unit

Equipotential bonding must be attached to one of the device's screw connections. This not only ensures safety but also increases the service life of your heating system by reducing electrochemical corrosion.

Step 6: Exhaust Floor Penetration



Example: Downward exhaust routing

Lead the exhaust floor penetration (Art. No. 0186150) through the prepared hole in the floor, ensuring the grille is facing downward.

The penetration is then securely bolted to the floor using the designated mounting holes.

Step 7: Applying Silicone to the Exhaust Pipe



High-temperature red silicone (Art. No. 091007, 32 ml tube) must be reapplied around the exhaust pipe. This ensures the exhaust system is optimally sealed.



Step 8: Fitting the Fresh Air Hose over the Exhaust Pipe

Guide the exhaust pipe (Art. No. 14-N000) through the fresh air hose (Art. No. 014120). Slide the hose clamps (Art. No. 014250) over the fresh air hose now, as this cannot be done after the exhaust pipe is connected.

An exhaust end piece (Art. No. 0754695) is recommended to prevent small animals from entering the system. If installing a silencer as an intermediate piece, use an approximately 10 cm long section of exhaust pipe.

Step 9: Connecting the Exhaust Pipe to the Heater



Secure the exhaust pipe to the heater using a T-bolt clamp (Art. No. 014244). For optimized sealing, the additional use of high-temperature silicone must be applied.

Step 10: Connecting the Fresh Air Hose to the Heater



Slide the fresh air hose over the connection on the heater and secure it with a hose clamp.

Note: For internal silencer installation, the exhaust pipe and fresh air hose must be connected to the silencer inside the vehicle. This specific silencer operates on the pipe-in-pipe principle, allowing it to be integrated into the exhaust duct within the vehicle. Afterward, connect the fresh air hose to the floor penetration and route the exhaust pipe to the outside.

Step 11: Inserting the Exhaust Pipe through the Floor Penetration



Guide the exhaust pipe through the center of the floor penetration.

Step 12: Connecting the Fresh Air Hose to the Floor Penetration

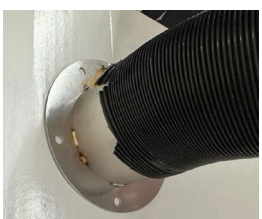

Slide the fresh air hose over the outer pipe of the exhaust floor penetration and fix it in place with the hose clamp (from Step 8).

Step 13: Mounting the Silencer Under the Vehicle

The silencer (Art. No. 070592) must be mounted to the chassis or a suitable position under the vehicle using the mounting brackets and securely fixed in place.

Step 14: Connecting the Exhaust Pipe to the Silencer



Slide the exhaust pipe onto one of the silencer's connections and secure it firmly using the previously installed T-bolt clamp.

Step 15: Connecting the Exhaust End Piece



Slide the section of the exhaust pipe cut off in Step 7 over the free end of the silencer and secure it with a T-bolt clamp. Insert the exhaust end piece into the exhaust pipe until it reaches the perforated structure, then fasten it with a T-bolt clamp.

Depending on the distance between the silencer and the exhaust end piece, it is recommended to additionally fix the end piece to the chassis to prevent it from falling off due to vibrations.

Step 16: Connecting the Lines

Connect the heating circuit lines, fresh water lines, and the fuel line to the heater or the pre-installed connections. If not already done in Step 3, the air vent must be installed now. Either an automatic or a manual air vent can be used.

Description	Art.-No.
Exhaust Pipe	14-N000
Exhaust Pipe End Piece	0754695
Exhaust Floor Penetration	0186150
Fresh Air Hose	014120
Hose Clamp	014250
Hinged Bolt Clamp	014244
Muffler	070592

Step 17: Installing the HeatMate® control unit

If the HeatMate® was previously removed, reattach it to the heater during this step. Connect the electrical plug connectors to the terminals on the heater. Follow the installation layout shown in the illustration. Ensure that all connectors click into place correctly to guarantee a reliable electrical connection.

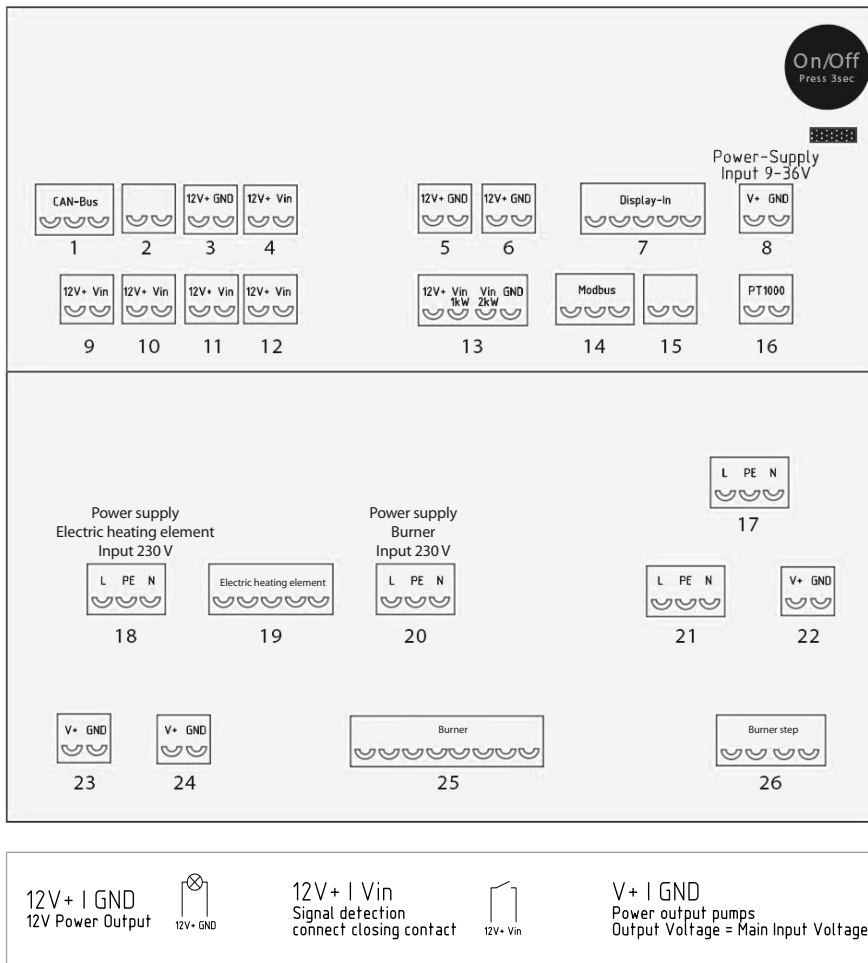

1. CAN bus
2. not assigned
3. Thermal stop
4. On/Off potential-free (close 3sec=on/off)
5. Inverter wake-up
6. Fault message
7. Display
8. DC power supply
9. Fresh water warm plus
10. Auto tank control
11. Room thermostat 1
12. Room thermostat 2
13. Electric heating on/off (close Vin(1kW) for 1kW, close Vin(2kW) for 2kW, both close for 3kW)
14. Modbus
15. not assigned
16. Boiler temperature
17. Burner preheating
18. AC-In electric heating element
19. Output electric heating element
20. AC-In burner
21. Safety temperature limiter
22. Circulation pump
23. Pump heating circuit 2
24. Pump heating circuit 1
25. Burner
26. Burner stage

Step 18: Connecting the power supply

The heater is equipped with two separate 230 V power supplies, which are labeled ‚Mains‘ (Netz) and ‚E-Heater‘ (E-Heizung) accordingly. The electric heater can therefore be operated from a separate power source, independent of the burner and the controller. This configuration is particularly advantageous when battery capacity is limited, as the E-Heater can be supplied exclusively from outside the vehicle in this case. A 6 A fuse is required for ‚Mains‘, while the ‚E-Heater‘ must be fused at 16 A, as it handles loads of up to 3 kW.

In addition to the controller, the 9–36 VDC supply powers the circulation pump (not included in the scope of delivery) as well as an internal circulation pump. The necessary fusing must therefore be designed for 40 W plus the power consumption of the pumps used.

The outputs for Pumps 1 and 2 are equipped with self-resetting 3 A fuses, which limits the available power. If a fuse trips, switch the device off and leave it off for a few minutes to allow the fuse to reset automatically.

Filling and Bleeding the System

Antifreeze

The heating system must be filled with a water-antifreeze mixture to prevent system components from freezing. Conventional antifreeze products based on crude oil are typically labeled as „harmful to health and irritating.“ Therefore, the use of climate- and environmentally friendly vegetable-based antifreeze (Art. No. 190094), specifically developed for heating systems, is recommended. These antifreeze agents are not hazardous to health and pose no danger to the user or the environment.

To determine the required amount of antifreeze, roughly calculate the volume of the heater itself, as well as the volume of the installed pipes and the consumers used (e.g., towel rails, water-to-air heat exchangers, convectors). Additionally, include a reserve of at least 10% to compensate for spilled amounts and residual quantities in the reservoir. In an open, pressureless system, this refers to an expansion tank; in a closed, pressurized system, it refers to a pressure expansion vessel.

Flushing Unit



To fill the system, the use of a flushing unit is recommended. This includes a powerful pump and a storage tank for the heating fluid. These types of units are also referred to as „solar flushing units“ or „filling stations.“

Fill the antifreeze into the flushing unit's reservoir according to the manufacturer's instructions. If a pressurized system is being filled, the normal operating pressure is 1.5 bar.

Step 1: Connecting the Lines

Connect the two lines of the flushing unit to the double-T connection on the heating system. Ensure that the line from the flushing pump is connected toward the heating circuit, and the return line to the reservoir is connected toward the heater. This ensures that the fluid circulates through the installation via the flow pipe first and through the boiler last.

Step 2: Instructions for Flushing the System

Preparation:

Ensure that all valves in the heating circuit are fully open and there are no blockages. For systems with two heating circuits, it is possible to flush only one circuit first while excluding the other by shutting it off. The second circuit can then be flushed separately.

Important: Before starting circulation in open (pressureless) systems, you must shut off the expansion tank to prevent overflow!

1. Starting the Flush:

Start the flushing pump and slowly open the shut-off valves at the double-T piece to the heating circuit to avoid sudden pressure peaks in the lines. Ensure that the system's maximum operating pressure is not exceeded during this process.

2. Flushing Duration and Observation:

Flushing takes time. Once the fluid has flowed through the entire heating circuit, returned to the reservoir, and all air has been purged, let the flushing process run continuously for 30 to 60 minutes. Watch the flushing unit's reservoir to ensure that no more air bubbles are visible. This procedure ensures a thorough cleaning of the heating circuits and optimizes system performance.

3. Ending the Flushing Process:

When no more air bubbles can be seen in the return line, stop the circulation pump and simultaneously shut off the lines going to and from the flushing unit at the double-T piece. This prevents static pressure from pushing heating fluid back into the reservoir and drawing air into the system. Disconnect the lines from the flushing unit.

Step 3: Bleeding the System

First, let the heating system rest for a few minutes to allow air bubbles to collect and settle at the bleeding points. Then, begin the bleeding process at the lowest point, which is typically at the heater. If an automatic air vent is installed here, wait until no more air is being discharged and the hissing sound stops. Continue by opening all other bleeding points in the system one after the other to release the air.

After the initial bleeding, it is recommended to perform at least one or two additional passes to ensure all air bubbles are removed. If air remains in the system, it can be helpful to move the vehicle during the process to direct remaining air bubbles toward the bleeding points. Once the system is completely free of air, the line to the expansion tank can be opened.

The bleeding process requires patience, but a well-bled system ensures proper circulation and prevents issues such as expansion tank overflow or insufficient heating performance.

Step 4a: Establishing Operating Pressure (Closed Systems Only)

Close the return connection to the flushing unit and slowly build up pressure in the system with the pump switched on. Always monitor the pressure gauge during this process. The normal operating pressure is 1.5 bar.

Step 4b: Setting the Expansion Tank Level (Open Systems Only)

Fill the expansion tank with antifreeze until the liquid reaches the lower edge of the tank. Avoid overfilling, as the volume of the heating fluid expands when it heats up during operation. Additionally, small residual air bubbles may still be in the system, which could also lead to an overflow.

During operation, the fluid level should not exceed two-thirds of the expansion tank when the system is hot to ensure proper function and sufficient pressure compensation.

Step 5: Starting Circulation and Re-Bleeding

Start the heating circuit pump to begin operation of the heating system. If a SCHEER pump is installed and you notice that the pump starts briefly but stops immediately, this indicates that there is still air in the pump housing. In this case, the pump's integrated dry-run protection kicks in to prevent damage caused by an insufficient fluid supply.

This behavior suggests that the system may not have been flushed sufficiently. Re-check the bleeding process and ensure that the heating circuits are completely free of air before restarting the pump.

Commissioning

Ensure that there is sufficient fuel in the tank so that fuel can be drawn from the heater's extraction point.

Operating the heater without heating fluid can lead to the destruction of the heating unit. Ensure that the heating system is completely filled before proceeding with commissioning.

Open all valves in the fuel line.

Step 1: Starting the Heater Unit

Press the main switch of the heater to turn it on. The display will show the current boiler temperature. If the error message „Check AC burner“ appears during the initial commissioning, please refer to the „Trouble-shooting“ section.

Step 2: Starting the Burner



If the boiler temperature is below 50°C, a 60-second preheating phase starts automatically. Afterwards, the burner starts automatically.

The blower starts and the diesel pump simultaneously begins to prime fuel. Monitor the vacuum gauge on the fuel filter. The needle may deflect slightly but must not reach the red zone.



Note: If the gauge moves into the red zone, there is either a blockage in the fuel line or the line diameter is too small, resulting in excessive suction resistance.

After approximately 10 seconds, the burner switches to the ignition sequence. If insufficient fuel has been primed at this point, the burner will enter fault mode. This is indicated on the HeatMate® display.

The message „Preheating“ is shown on the HeatMate® display until the target setpoint is reached for the first time.

To reset the burner and restart the ignition process, press the reset button. Once successfully reset, the red light will go out and the starting sequence begins again.

Note: The reset button must not be pressed for longer than 2 seconds!

Repeat this process several times until the fuel filter is sufficiently filled. With very long diesel lines, air bubbles in the line can obstruct suction. Frequent resetting may be necessary in this case.

The lower filter bowl containing the filter element must be completely full. In the upper sight glass, a fill level of approximately 3 cm must be reached.



Note: No bubbles or foam should form in the filter during the priming process. During initial commissioning, some bubble formation may be observed at first. If this does not disappear after a maximum of 60 seconds, check the fuel line for leaks.

As soon as the fuel filter is filled, the burner start sequence begins. The initial burner start may be somewhat uneven due to an initially inconsistent fuel supply. From the second start onwards, the burner should start smoothly and quickly.

Step 3: Heating the System

Initially, heat the boiler only and continuously monitor the level in the expansion tank. Next, open the valves for the heating circuit circulation. Observe whether the level in the expansion tank rises gradually. A sudden and sharp increase indicates air bubbles in the system.

Ensure that all sections of the system heat up evenly. If a line remains cold beyond a certain point, this may indicate a blockage or trapped air within the line. In this case, additional venting measures are required. Refer to „Filling and Venting the System“ -> Steps 3-5.

Step 4: Testing Domestic Hot Water Heating

Draw hot water from a tap or outlet point.

Troubleshooting

	Maintenance Interval
Burner fails to start despite frequent resetting; diesel filter is empty or insufficiently filled	<ul style="list-style-type: none">• Does the vacuum gauge on the filter move into the red zone when the burner starts? -> The line may be blocked; the pump cannot prime/suction.• Do bubbles or foam rise in the oil filter when the burner starts? -> Check the diesel supply lines for leaks.
Fresh water is not heated, or not heated sufficiently, and the boiler temperature does not drop / the burner switches off despite fresh water consumption	<ul style="list-style-type: none">• Bleed/vent the heating system. For open, pressureless systems: Move the vehicle (to help release trapped air).• Check the potable water supply for leaks.
Fresh water is not heated sufficiently	<ul style="list-style-type: none">• Check the fresh water flow rate -> Reduce if necessary (water temperature should then be approx. 50°C).
HeatMate® has reached the target temperature, but the heating circuit is not getting warm	<ul style="list-style-type: none">• Bleed/vent the system; air bubbles in the lines are preventing circulation.• If necessary, flush/purge the system again.
Expansion tank overflows (in an open, pressureless system)	<ul style="list-style-type: none">• Check whether the volume of the expansion tank is sufficient (expansion of a 50/50 glycol-water mixture is approx. 4%).• Bleed/vent the system (spontaneous expansion of air bubbles leads to overflowing).
Electric heater is not heating	<ul style="list-style-type: none">• Check the power supply (verify if there has been an automatic shutdown by the Battery Management System/BMS).• Check plug connections.• Check activation on the control unit.• If the system was operated without heating fluid, the electric heater may be defective due to the resulting high temperatures. Please contact the manufacturer.
Heater produces soot / strong odor	<ul style="list-style-type: none">• Is the fuel supply in the filter free of bubbles/foam? -> No: Check fuel line for leaks.• Is the fresh air supply interrupted or insufficient?• Is exhaust gas entering the fresh air intake? -> YES: Seal the exhaust system.• Check exhaust emission values; if necessary, verify burner settings.
Diesel odor at the heating system	<ul style="list-style-type: none">• Route the vent hose of the diesel filter back into the heater housing (transparent silicone hose on the fuel filter)

Troubleshooting

<p>After switching on, the HeatMate® displays the error ‚Check AC polarity‘</p>	<ul style="list-style-type: none"> • Check whether the 230V power supply is correct (Phase to Phase). • Rotate the Schuko plug and wait 30 seconds. • Verify that the inverter generates a clean 230V potential from L (Phase) to PE (Ground). If necessary, a bridge from N to PE must be installed or a corresponding setting must be made in the inverter configuration (follow the inverter manufacturer’s instructions).
<p>Device does not switch on</p>	<ul style="list-style-type: none"> • Check whether 9–36V power supply is present at the HeatMate (Connection 8) (ensure correct polarity). • Following a short circuit in the DC power supply, an internal fine-wire fuse must be replaced. * Please contact the manufacturer for this purpose. * Unauthorized opening of the control housing will void the warranty.
<p>The heating circuit pumps are not operational.</p>	<ul style="list-style-type: none"> • Ensure that the pump’s input voltage and the onboard voltage match. Is the pumps’ dry-run protection active (evidenced by recurring starting and stopping)? -> Bleed/vent the system. • Are the heating circuits activated on the HeatMate® control unit (LED above the button is lit)? • Are the connected thermostats switching the demand contact? • Ensure that the contact at connection 9 is not closed (unplug the connector).

Water heater micro Installation instructions

SCHEER
Heizsysteme & Produktionstechnik GmbH
Chausseestr. 16
D-25797 Wöhrden
Tel.: + 49 (0) 4839 / 905-0
info@scheer-heizsysteme.de
www.scheer-heizsysteme.de